

G6000UG SERIES

BI-DIRECTIONAL PROGRAMMABLE AC SOURCE-LOAD SYSTEM

Oct. 2025 Version: A3.3

KEWELL TECHNOLOGY CO., LTD.

www.kewelltest.com



CONTENTS

1 Summary	1
2 Product Highlights	2
3 Product Specifications	3
4 Product Features	6
5 Appearance	14

1 Summary

The G6000UG Series is a bi-directional programmable AC source-load system featuring high precision, high power density, and high dynamic performance. It supports adjustment of three phases separately, while having LIST/PULSE/STEP and other programming functions to simulate the disturbance characteristics of grid voltage and frequency. It also has waveform editing, harmonic and inter-harmonic modes, able to simulate abnormal grid conditions and test the grid tolerance of the device under test (DUT).

The G6000UG Series bi-directional programmable AC source-load system is widely applicable to testing for photovoltaic (PV) & energy storage, electric vehicle, AC and DC charging pile, and tests performed by research institutes and colleges and universities.



The G6000UG Series appearance

2 Product Highlights

2.1 Ultra-high Power Density

Up to 3U/18kVA per device, compact, lightweight, and space efficient.

2.2 AC & DC in One

AC and DC output in one, support up to 650Vdc output, and the max. current in DC mode equals the AC rms.

2.3 Instantaneous Interruption

Able to simulate instantaneous grid interruption of as short as 1ms.

2.4 Source & Load in One

Source and load functions in one, one-button switching between CC/CV priority, meeting the test requirements of different scenarios, such as testing of PV & energy storage, electric vehicles, and AC/DC charging piles.

2.5 Flexible Parallel Connection

A single G6000UG Series device can reach the max. power of 18kVA. Through flexible parallel connection, it can be expanded to higher power, and the performance parameters of the parallel machines are consistent with a single device.

3 Product Specifications

3.1 Model Description

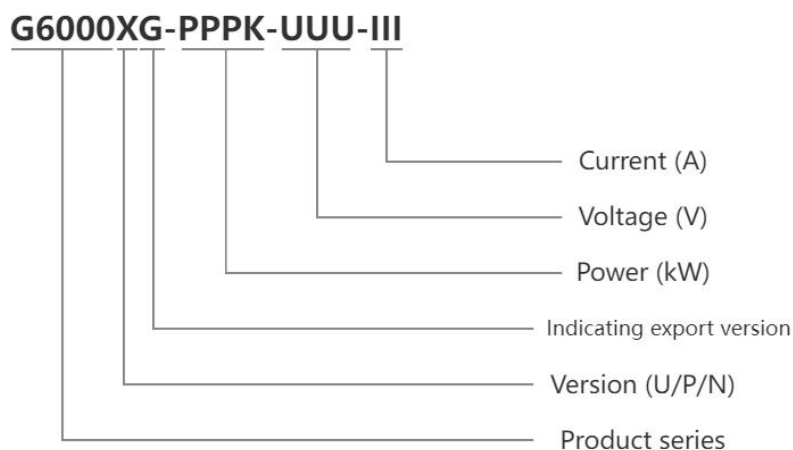

Example: G6000UG-18K-0450-0090

3.2 Technical Specification

Model		G6000UG-18K-0450-0090	G6000UG-12K-0450-0090
Rated power [kVA]		18kVA	12kVA
Voltage range [V]		0-450V	
Rated current [A]		90A	
Output phase		Single phase/Three phase	
AC Input			
Rated values	Input voltage	342V ~ 528V	
	Input frequency	47 ~ 63Hz	
Phase		Three-phase four-wire	
Max. input current		35A	23A
Power factor		0.99	
AC Output			
Rated values	Output voltage	L-N/0 ~ 450V, L-L/0 ~ 779V	
	Output current	30A @three phases	
		90A @single phase	
Output power	18kVA	12kVA	
Voltage	Resolution	0.01V	
	Accuracy	≤0.05%+0.05%F.S.	
	Load regulation	≤0.05%F.S.	
	Line regulation	≤0.01%F.S. @10% variation	
	uTHD	< 0.5% @50Hz/60Hz	
< 1% @15Hz ~ 200Hz			
Current	Resolution	0.01A	
	Accuracy	0.1%+0.1%F.S.	

	Peak	90A @three phases	
		270A @single phase	
Frequency	Setup range	15Hz ~ 200Hz	
	Resolution	0.01Hz	
	Accuracy	0.01%	
Phase	Setup range	0 ~ 359.9°	
	Accuracy	±0.1°	
	Resolution	±0.1°	
Harmonics	Order	2 nd -100 th , arbitrary voltage harmonics	
	Content	40%	
DC output			
Rated values	Output voltage	650V	
	Output current	90A	
	Output power	18kW	12kW
Voltage	Resolution	0.01V	
	Accuracy	≤0.1%F.S.	
	Load regulation	≤0.025%F.S.	
	Line regulation	≤0.01%F.S. @10% variation	
Load parameters			
Voltage	Input voltage	30-450V	
	Resolution	0.01V	
	Accuracy	0.1%+0.1% F.S.	
Current	Input current	90A @single phase 30A @three phases	
	Resolution	0.01A	
	Current accuracy	0.2% + 0.2% F.S.	
Frequency	Frequency range	30-100Hz	
	Resolution	0.01Hz	
	Accuracy	0.1%	
Power	Input power	18kVA @single phase 6kVA @each phase	12kVA @single phase 4kVA @each phase
	Resolution	1VA	
	Accuracy	0.4% +0.4% F.S.	
Power factor	Range	-1~1	
	Resolution	0.001	
Crest factor	Range	1.414~3	
	Resolution	0.001	
Resistance	Range	0.3~333.33Ω, single phase 0.9~1000Ω, three phases	
	Resolution	0.001Ω	
	Accuracy	0.3%+0.3% F.S.	
General parameters			
Withstand voltage		1500Vdc	
Peak efficiency		90%	
Degree of protection		IP20	
Storage temperature		-20°C ~ +70°C	
Operating temperature		0 ~ 40°C	
Humidity		0 ~ 90%RH, 25°C non-condensing	
Altitude		2000m	
Communication interfaces		RS232/LAN/USB/Analog IO/Digital IO	
Dimensions (mm)		699 (D)×445 (W)×133 (H)	
Weight		40kg	

3.3 Optional Configuration

Optional Function	
GPIB communication interface	GPIB communication

4 Product Features

The G6000UG Series features flexible operation with AC, DC and AC+DC output modes. In AC mode, it supports three-phase sync./ three-phase independent/ single phase operation, where users can set amplitude, frequency, phase, etc. separately. There are output modes including step, list, pulse, harmonic/inter-harmonic superposition, and HVRT/LVRT modes. The programming data can be saved, imported and exported.

4.1 Sine Wave Mode

In this mode, users can set the voltage, phase, amplitude, and frequency of the output, minimum setup step size: 0.01V, 0.01Hz; the output mode can be three-phase sync./three-phase independent/single phase.

As shown in Figure 4-1, three-phase sync., the same voltage amplitude for each phase, with a phase difference of 120°.

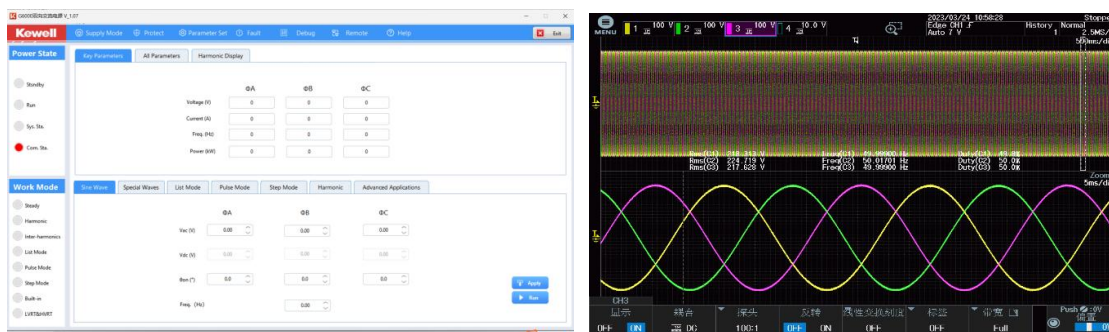

Fig. 4-1 Sine wave mode, three-phase sync. @220V, phase difference: 120°

As shown in Figure 4-2, when it is set to three-phase independent, users can test 3 independent DUTs at the same time, without needing additional hardware configurations.

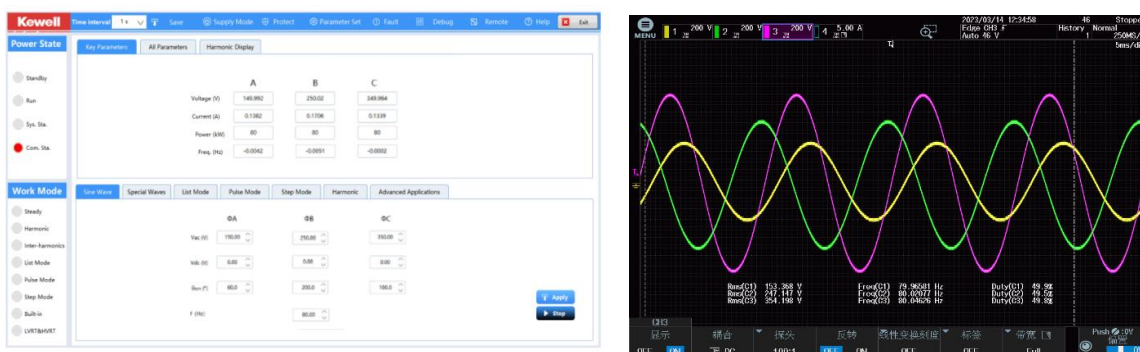

Fig. 4-2 Sine wave mode, three-phase independent @ different amplitude, Phase A: 60°, Phase B: 200°, Phase C: 100°

As shown in Figure 4-3, in single phase mode, it can output currents of 90A and above, meeting

customer requirements for testing high-current load.



Fig. 4-3 Sine wave mode, single phase @220V

Figure 4-4 and Figure 4-5 respectively show the AC+DC output mode and the DC+AC output mode;



Fig. 4-4 AC+DC @150V/50Hz, superimposed with 100Vdc, trigger @0°

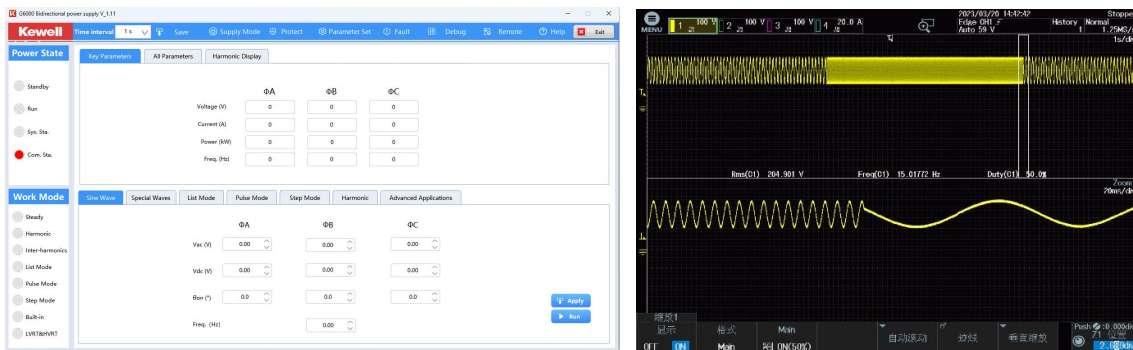

Fig. 4-5 DC+AC @200Vdc superimposed with 50Vac, frequency varying 15Hz -100Hz -15Hz

4.2 LIST/STEP/PULSE Mode

As shown in Figure 4-6 and Figure 4-7, the G6000UG Series has multiple programming output modes such as LIST, STEP and PULSE. STEP and PULSE modes provide single-step or continuous voltage variations to simulate grid interferences such as cyclic voltage dips, instantaneous high voltage, and descending voltage. As shown in Figure 4-8, LIST mode supports editing of more complex test waveforms, with up to 10 groups of steps, each group having up to 20 sequences to be set. The steps can be set in cycle,

and they are able to simulate a variety of conditions with voltage dips, interruptions and variations.

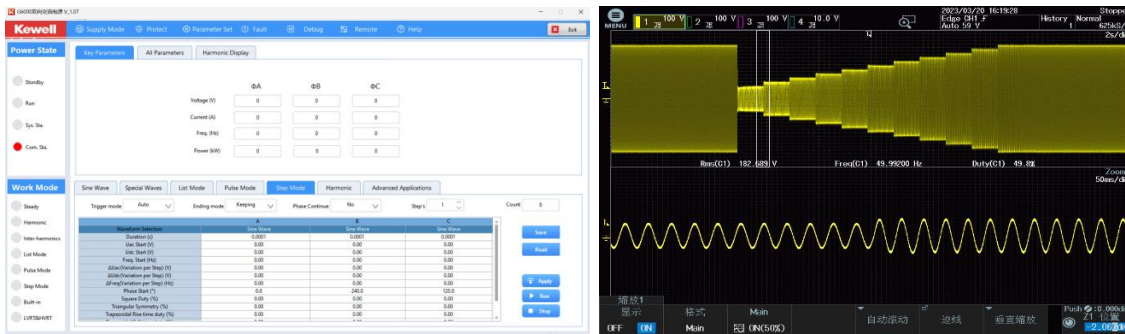

Fig. 4-6 STEP mode @voltage: 50-220V, frequency: 45-65Hz, gradient change in 10s

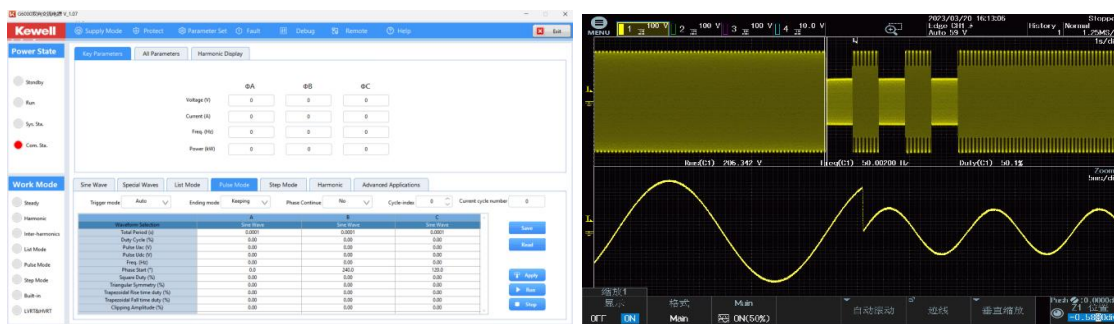

Fig. 4-7 PULSE mode @total cycle of 1s, pulse time: 50%, pulse voltage: 100V, frequency: 100Hz

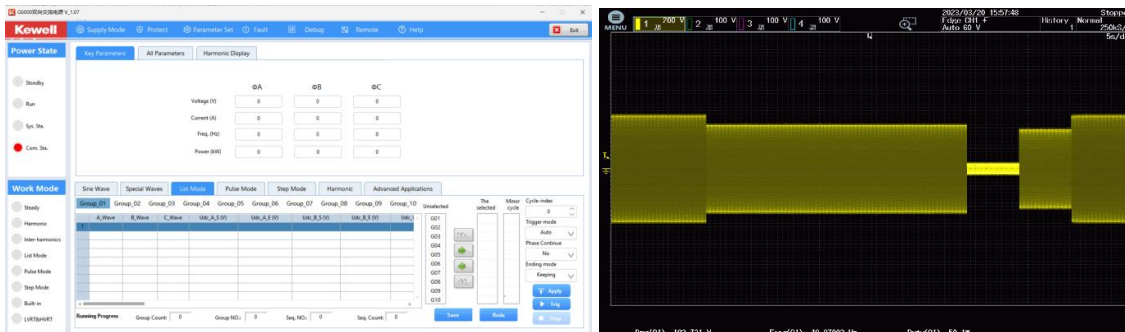

Fig. 4-8 LIST mode @voltage: 220-180-20-160V step change

4.3 HVRT/LVRT

With high voltage ride through (HVRT), low voltage ride through (LVRT), and high and low voltage ride through combined test functions, the G6000UG Series supports single-phase, two-phase and three-phase ride through tests, as shown in Figure 4-9, and high and low voltage ride through combined tests, as shown in Figure 4-10.

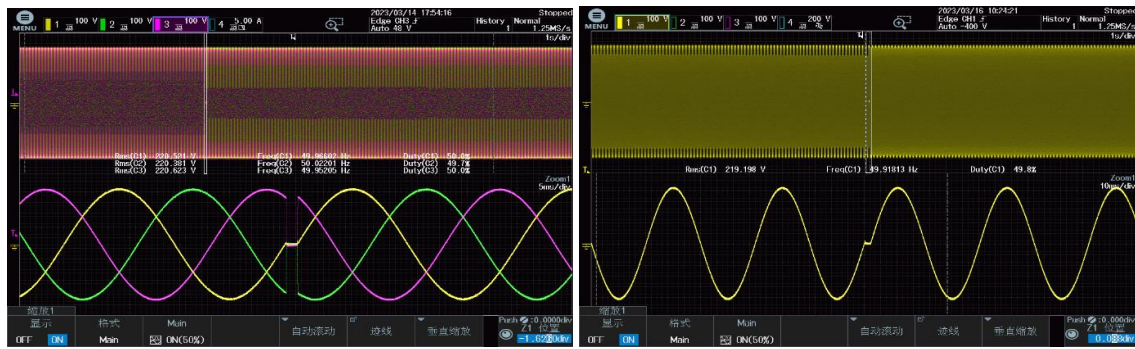

Fig. 4-9 Nominal voltage: 220V, phase A drop phase angle: 0°, ZVRT drop and recovery time < 1ms

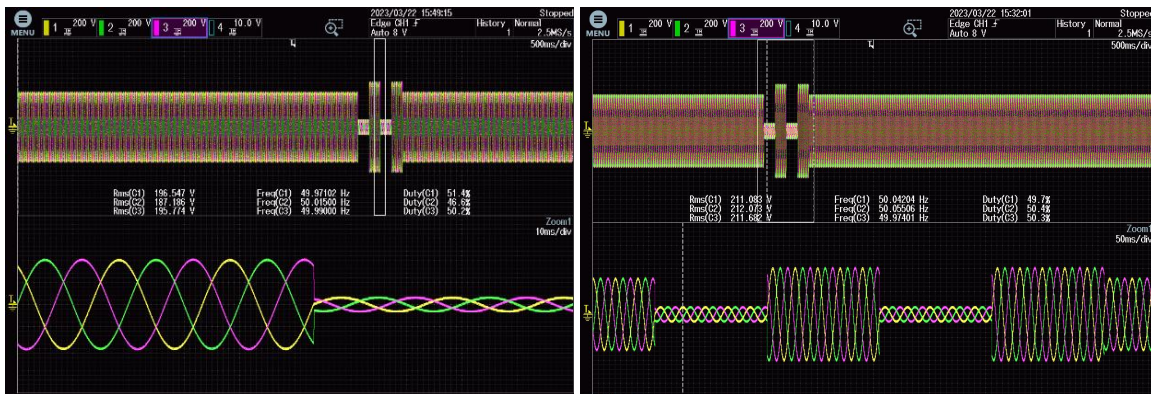

Fig. 4-10 Nominal voltage: 220V, LVRT: 20%, HVRT: 130%, phase A drop phase angle: 0°

4.4 Harmonic/Inter-harmonic Mode

As shown in Figure 4-11 and Figure 4-12, in harmonic superposition mode, the G6000UG Series supports 2nd-100th harmonic superposition, up to 99 kinds of harmonics to be superimposed simultaneously. Users can set the harmonic amplitude of each voltage component to simulate abnormal grid environment and thereby test the grid withstand of the DUT. The G6000UG Series also supports displaying harmonic content in the software interface, with 30 built-in harmonic voltage waveforms for users to call effortlessly with one click.

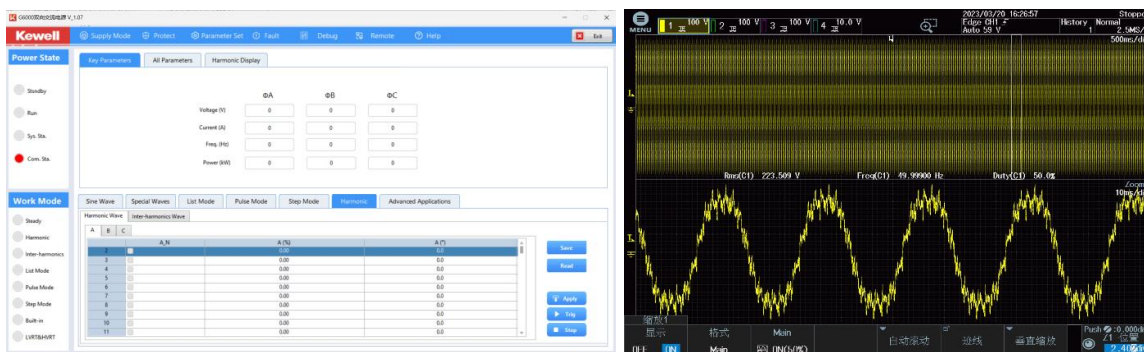

Fig. 4-11 Harmonic mode, fundamental wave @50Hz

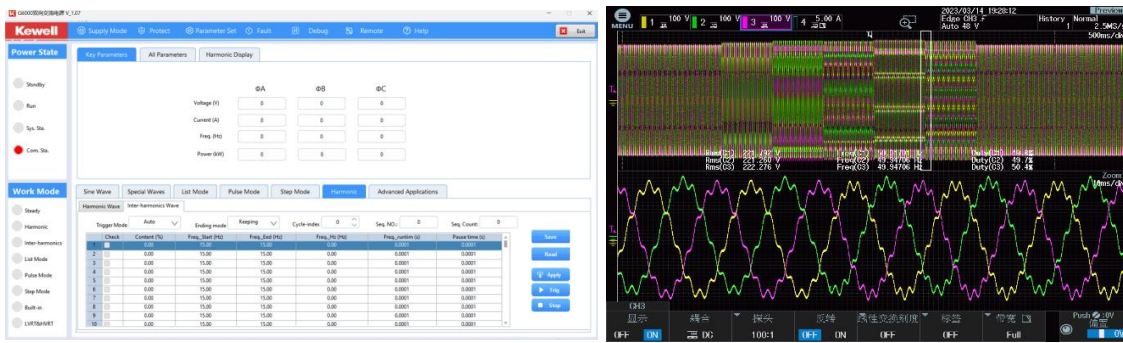

Fig. 4-12 Inter-harmonic mode, inter-harmonic content: 10%

4.5 Waveform Editing

The G6000UG Series has different types of built-in waveforms including triangle wave, square wave, clipped wave, trapezoid, and sawtooth. Users may call a selected waveform via upper computer or the menu and display it on the touch screen, different types of waveforms are shown in the figures below.

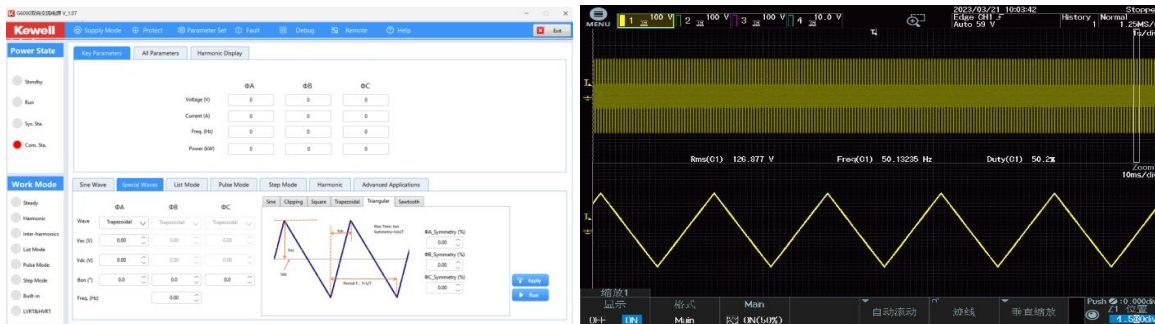

Fig. 4-13 Triangle wave @phase A-220V, 50% symmetry

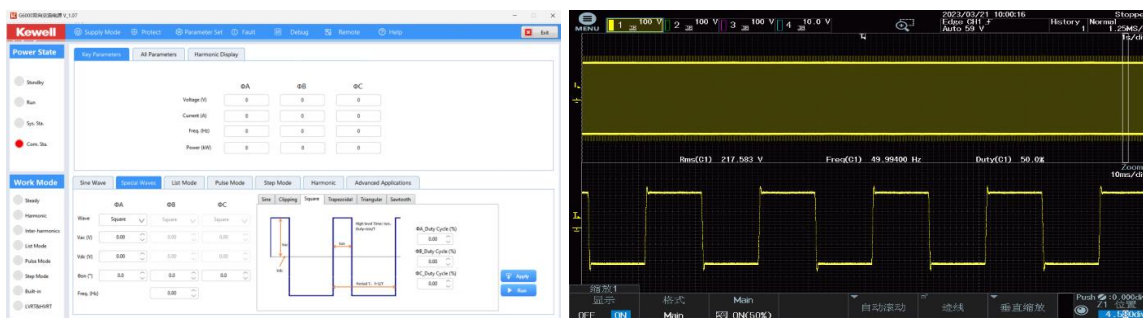

Fig. 4-14 Square wave @phase A-220V, 50% duty cycle

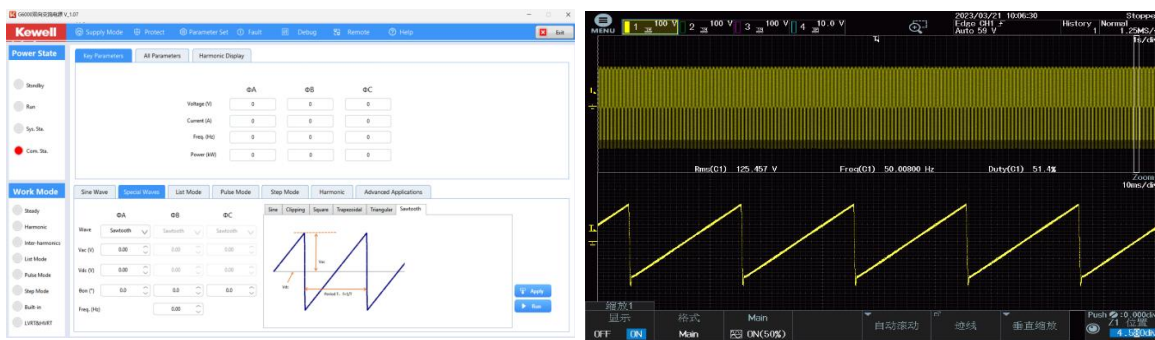

Fig. 4-15 Sawtooth @phase A-220V

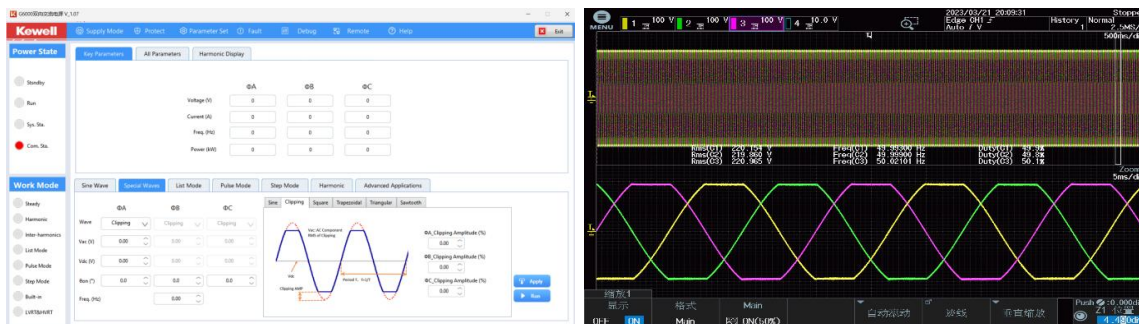

Fig. 4-16 Phase A-220V, 15% clipping

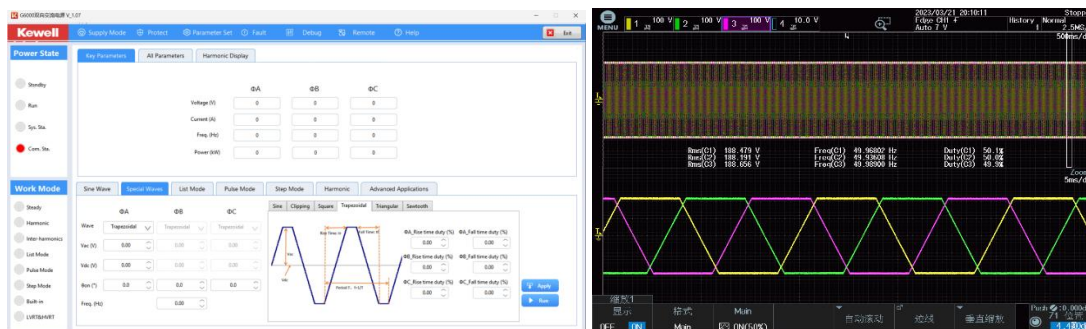

Fig. 4-17 Trapezoid, phase A-220V, rise time: 20%, fall time: 20%

4.6 Harmonic Display

The G6000UG Series features harmonic analysis function that covers voltage harmonic measurements and current harmonic measurements. In harmonic mode, it tests voltage and current total harmonic distortion (THD) and the phase difference between harmonics and fundamental. In addition, it supports multiple harmonic measurements and display of the results in a list in an intuitive way, as shown in Figure 4-18.

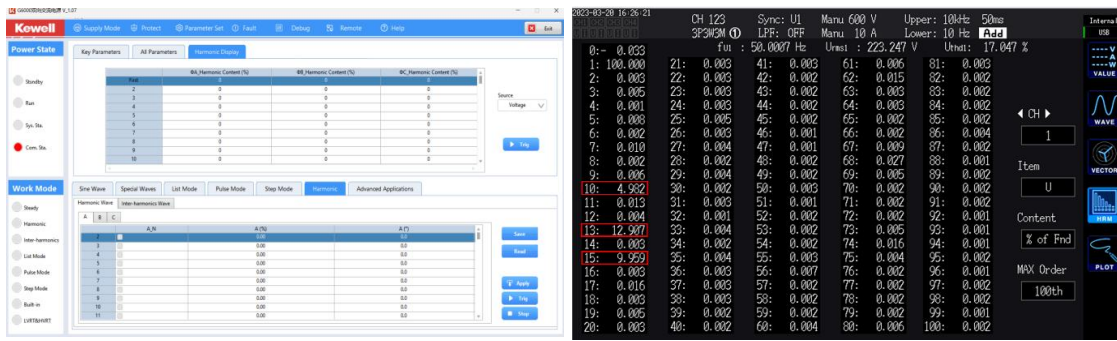

Fig. 4-18 Fundamental wave @50Hz, 10th-15th harmonic injection

4.7 Regenerative AC load

4.7.1 General AC load

The G6000UG Series is compatible with general AC load functions, supporting multiple output modes including constant resistance (CR), constant current (CC), constant power (CP), and power-quality (PQ). It allows for setting power factor and crest factor, and through List programming, multiple combined steps can be preset to achieve DUT dynamic loading, as shown in Figure 4-19.

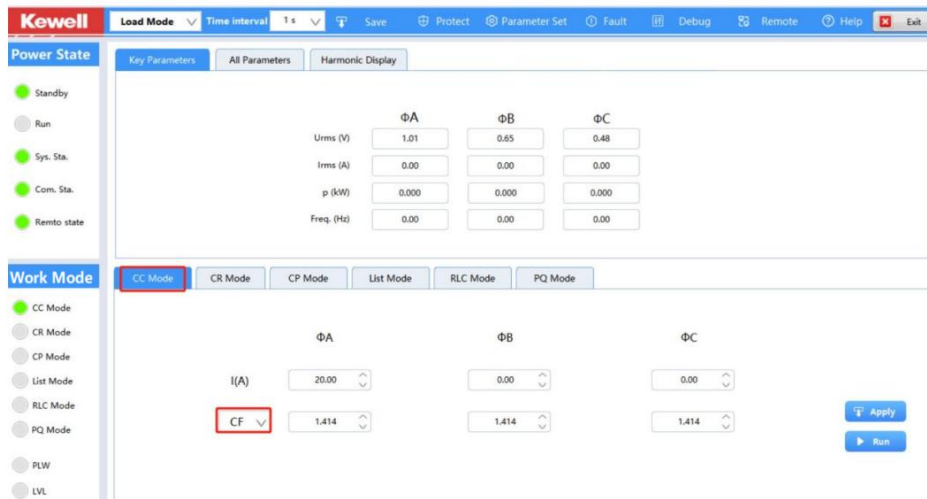

Fig. 4-19 Load mode

4.7.2 RLC Load

As shown in Figure 4-21, it incorporates 14 built-in RLC network models including R, RL and RC, enabling flexible adjustment of parameters to simulate various load characteristics. This feature is utilized to verify the performance of inverters, PCS, and other DUTs in different load impedance modes. In response to the off-grid test requirements of PCS, bi-directional on-board charger (BOBC), and other DUTs, the

automatic switching between source and load effectively simplifies the configuration of the automated test equipment (ATE) platform, thereby satisfying test requirements for applications such as vehicle-to-load (V2L) and vehicle-to-grid (V2G).

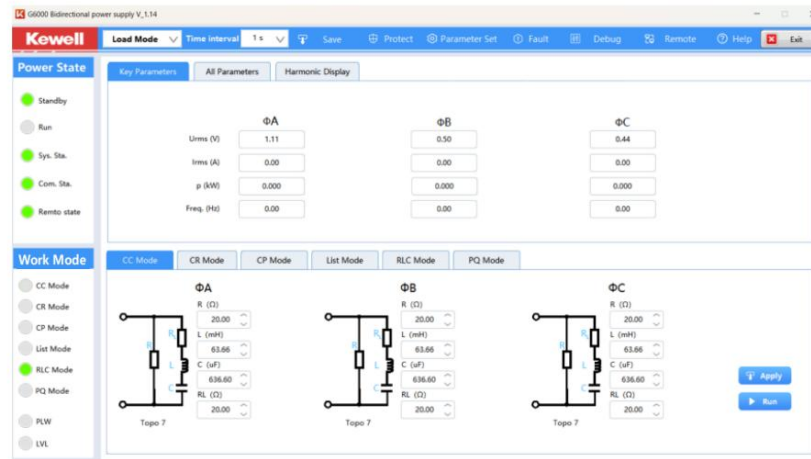

Fig. 4-20 RLC load mode

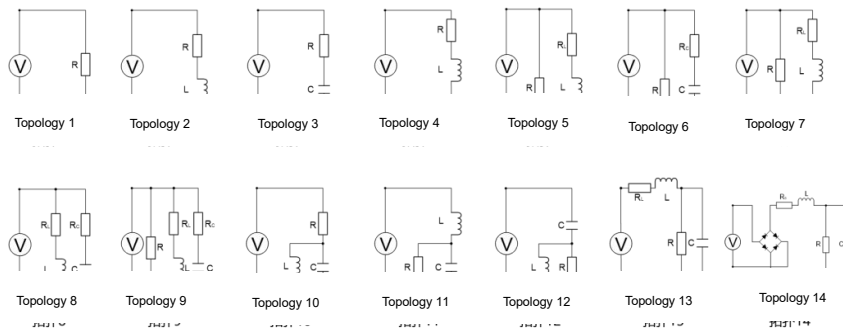

Fig. 4-21 RLC network model

5 Appearance

5.1 Single Device

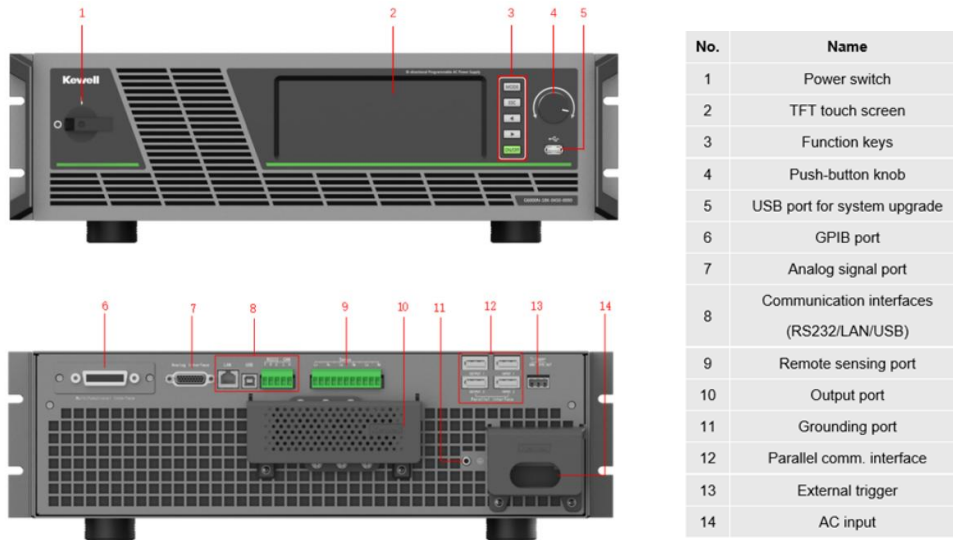
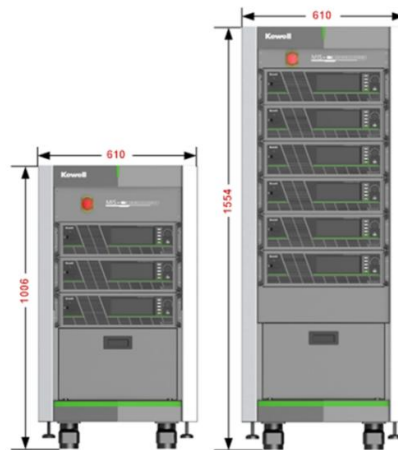

Fig. 5-1 G6000 Appearance

5.2 Parallel Connection



Model	Number	Dimensions (W*D*H)	Weight(Cabinet alone)
HK-15U	2~3 devices	610*1026*1006mm	130kg
HK-29U	4~6 devices	610*1026*1554mm	220kg

Note: Cabinet depth = 1026mm.

Fig. 5-2 Diagram of parallel connection (unit: mm)